

### AisleLok® Acrycell

#### Part Number

- 10108-001 ACRYCELL SEALING TAPE, .5"H x .71"W x 26.25'L, BLACK, 3 ROLLS
- 10108-002 ACRYCELL SEALING TAPE, 1"H x .71"W x 14.1'L, BLACK, 3 ROLLS
- 10108-003 ACRYCELL SEALING TAPE, .2"H x 1.18"W x 8.5'L, BLACK, 5 ROLLS

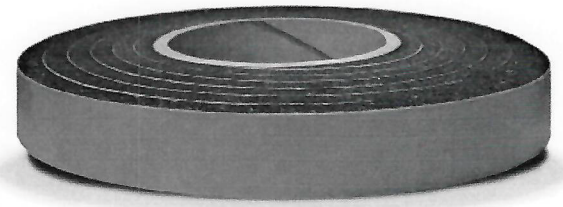

1" Acrycell Sealing Tape  
Part No. 10108-002

#### Each carton contains the following items:

- AisleLok® Acrycell Sealing Tape
- Installation Guide

### Tools and Preparation Required for Installation

#### Tools Required:

- Scissors or cutting blade

### Specifications

Part Number	Expansion Size	Rolls in Carton	Compressed Tape Minimum Effective Thickness	Expanded Tape Maximum Effective Thickness	Tape Width	Roll Length
10108-001	.5" (13mm)	3	.12" (3mm)	.60" (15mm) ± 10%	.71" (18mm)	26.25' (8m)
10108-002	1" (25mm)	3	.20" (5mm)	1.22" (31mm) ± 10%	.71" (18mm)	14.1' (4.3m)
10108-003	2" (50mm)	5	.35" (9mm)	2.0" (51mm) ± 10%	1.18" (30mm)	8.5' (2.6m)

### Installation Procedures

#### Installation of AisleLok Acrycell Sealing Tape

**Preparation:** Measure the gap to determine the ideal size of Acrycell Sealing Tape needed to properly seal the space. (See Product Chart) Prepare surface before mounting Acrycell Sealing Tape by wiping with a damp cloth then use lint free towel to dry.

1. Once the surface is clean and dry, begin peeling the backing off the Acrycell Sealing Tape to reveal the adhesive.
2. Attach tape by pressing the adhesive side to the surface of one side of the gap while unrolling and pressing to attach the tape straight and secure.  
Note: It is preferable to peel the adhesive backing off as the tape is being applied to avoid the inadvertent adhesion to other surfaces.
3. At the end of the gap, cut the tape to fit using scissors or a cutting blade. Any remaining tape stored for future use must be kept under pressure to prevent premature expanding. Recommended storage is immediate shrink wrapping or securing the loose end by applying storage tape around roll to keep material under pressure.
4. Tape will fully expand within 60-72 hours and longer in ambient temperatures below 70.

- 1 Position Begin peeling the backing off the Acrycell Sealing Tape to reveal the adhesive.

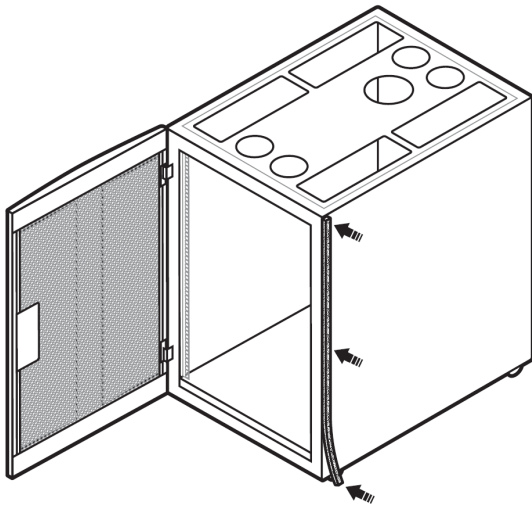
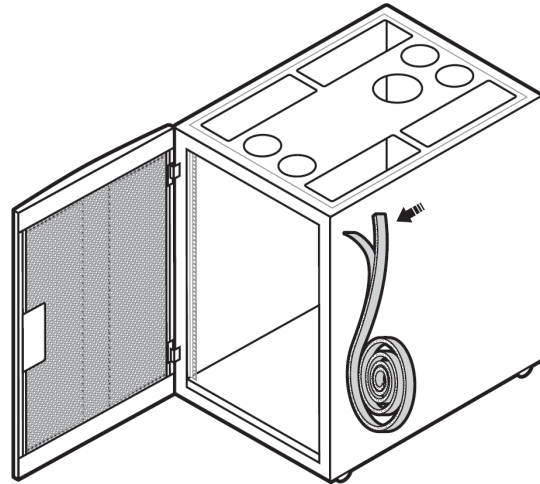

- 2 Attach tape by pressing the adhesive side to the surface of one side of the rack while unrolling and pressing to attach.

- 3 At the end of the gap, cut the tape to fit. Allow ample time for tape expansion to form secure seal.

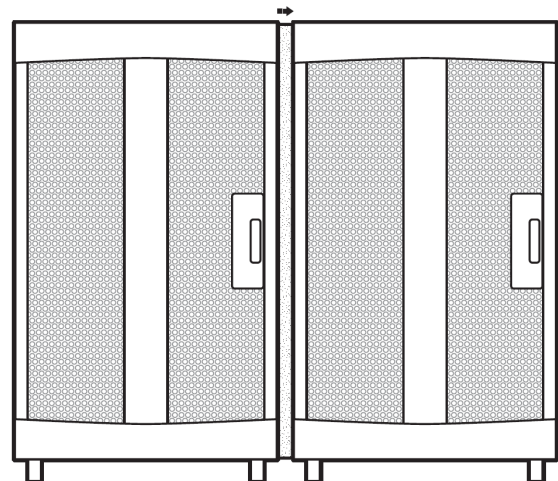

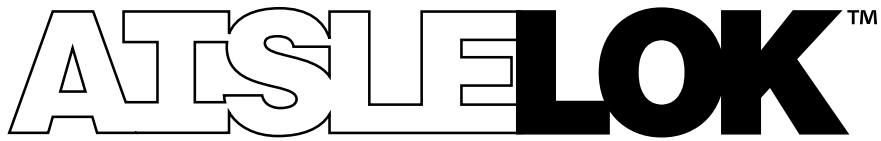

## Installation Guide

### General Information

#### Effective Seal Between Racks

In order to provide the best containment of hot and cold air in the data center the gaps between the racks must be sealed. AisleLok Acrycell Sealing Tape expands to fill gaps between racks and prevent the mixing of hot and cold air, thus improving data center energy efficiency and a reduction in hotspots that threaten system reliability.

#### Maintaining Proper Cooling of Equipment

Failure to follow computer manufacturer's guidelines for maintaining proper cooling may result in the overheating of equipment. Before sealing gaps between racks, ensure that there is adequate airflow to the intake side of the computer equipment or cabinets through devices such as perforated floor tiles or grates. Achieving proper airflow to the intake side of computer equipment and/or cabinets is the responsibility of the customer.

#### Safety Requirements

Installers must be familiar with standard safety and risk management practices when working on server rack equipment or in data center environments.

#### Customer Support

If you have any questions, please contact us direct at (505) 798-0200, or Toll Free at (888) 982-7800. Email us at [info@upsite.com](mailto:info@upsite.com)

# Insrallation Guide

## Limited Warranty

Upsite Technologies, Inc. (the *Company*) warrants to the original purchaser that products delivered hereunder will be free of defects in materials and workmanship for a period of twelve (12) months from the date of purchase (the "Warranty Period").

The *Company* shall, at its option, within the Warranty Period, either repair or replace free of charge, any product or part thereof found, upon the *Company's* inspection, to be defective in materials and workmanshio, and will return the repaired or replaced product to the purchaser at *Company's* expense.

For warranty service and shipping instructions, contact the *Company* at the telephone number shown below. If the product is under warranty and the defect appears to be covered by this Limited Warranty, the *Company* will issue to the purchaser a Notice of Authorization For Warranty Return. Products returned to the *Company* for warranty service must be accompanied by a statement of defect, the Notice of Authorization for Warranty Return provided by the *Company*, and proof of purchase.

This Limited Warranty is conditioned on the following:

1. The *Company* must be notified within 12 months of purchase and have been given the opportunity of inspection by return of any alleged defective product free and clear of all liens and encumbrances to the *Company* or its manufacturer; and
2. The product must not have been abused, misused, or improperly maintained, and/or non-Upsite authorized repair performed during such period; and
3. Such defect has not been caused by corrosion or exposure to other than ordinary wear and tear; and
4. The installation and use of the product has been in accordance with the manufacturer's instructions and not been modified or customized to include but not limited to cut, resized, burned, glued, bent, re-shaped, disassembled, attachments added to, improperly installed or used in a manner other than intended.

The company makes no other express or implied warranty or representation of any kind whatsoever including any warranty of merchantability or fitness for a particular purpose and all such other warranties are hereby included.

The *Company's* maximum liability hereunder is limited to the purchase price of the product. In no event shall the *Company* be liable for any consequential, indirect, incidental, or special damages of any nature arising from the sale or use of the product, whether based in contract, tort, strict liability, or otherwise.

Note: Some jurisdictions do not allow limitations on incidental or consequential damages or how long an implied warranty lasts, so that the above limitations may not fully apply. This warranty gives specific legal rights and you may also have other rights which may vary from jurisdiction to jurisdiction.

For complete warranty and repair information Call (888) 982-7800 or visit [upsite.com](http://upsite.com)

U.S. and International Patents Pending



☎ 888-982-7800

✉ [sales@upsite.com](mailto:sales@upsite.com)